



YOUR BEST CHOICE

Quality - Power - Economy - Reliability

www.desislava20granulators.com

Desislava 20 Granulators Company
PLASTIC AND RUBBER RECYCLING TECHNOLOGIES

DUNS No: 55-257-6134

SHREDDING EQUIPMENT

THE SHREDERS KOMPASS

[THE GRANULATORS KOMPASS](#)

Two Shafts Shredders Kompass	400 x 420
Single Shaft Shredders Kompass	320 x 600



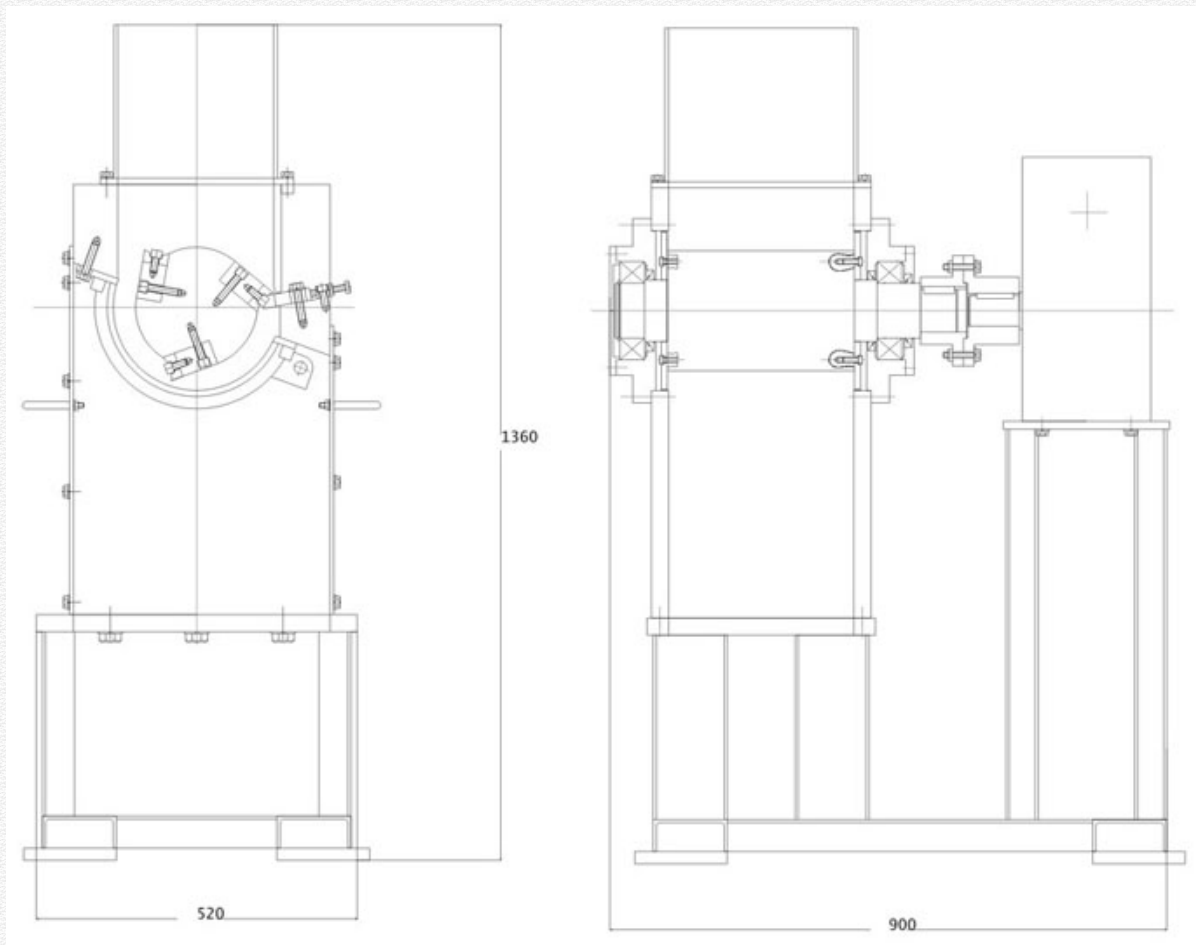

Warranty: 12 months from the date of delivery (the warranty do not include the cutting instruments, screen and the servicing).

If it is needed to be sent spare parts the warranty terms cover the cost of the spare parts only Ex Works

(The cost of the transport is not included in the warranty terms).

A complete technical documentation and instructions for assembly and operation.

Sincerely Yours,
Konstantin Tomov,
President of Desislava 20 Granulators Company
Tel./fax: +359 2 870 3295
Mobile: +359 986 872 859

URL: <http://www.desislava20granulators.com>

CONTACT: ktomov@usa.com
info@desislava20granulators.com
support@desislava20granulators.com
desislava20@fastbg.net

ADDRESS: 9 Zlatovrah Str., 1164 Sofia, Bulgaria

Single Shaft Shredder Kompass 320 x 600

All body of the machine is manufactured from	1045 steel
All bolts are made in	Germany
The fly knives	Each piece have 4 cutting edges
Hopper	Sound-proof
The reduction gear is made in	Italy
The motor will have	IP54+ thermal protection
The Bearings FAG	With brass separators and anti-vibration design
The motor control is manufactured with units from	“Square D“- the US or “Telemecanique”- France
The machine will be equipped with	Additional set cutting tools and additional screen

Two Shafts Shredder Kompass 400 x 420

Volume of the Hopper	0.5 cubic metres
Cutting Chamber	400 mm x 420 mm
Shafts	2 pcs.
Speed of the shafts 1/2 (rpm)	28 /14
Thickness of the cutting disc	15 mm
Cutting discs	24 pcs.
El. Motor	15 kW # 1'500 rpm # 220/380 V # IP54 + thermal protection
The motor control is manufactured with units from	“Square D“- the US or “Telemecanique”- France.



**9 Zlatovrah Str.1164 Sofia, Bulgaria tel./fax: 359 2 870 3295; Mobile Phone:
359 896 872 859**

<http://www.desislava20granulators.com> and <http://www.geocities.com/desislava20> ;

E-mail: ktomov@usa.com and desislava20@fastbg.net



Time Zone: GMT + 02:00

Working Time

The Office: 09:00 am - 17:30 pm (from Monday up to Friday)

E-mail & Fax : 24 hours / 7 days week