

# *Master* **WATCHMAKING**

## *Lesson 13*

**FACTORY BALANCE HOLE JEWELS  
AND ROLLER JEWELS**

CHICAGO SCHOOL OF WATCHMAKING *Founded 1908 by* THOMAS B. SWEAZEY

Copyright 1948, 1952, 1956, 1961 by

Byron G. Sweazey

Copyright © 1969, 1972, 1978 by

Chicago School of Watchmaking

All Rights Reserved

Printed in the United States of America

## INTRODUCTORY INFORMATION

No doubt you have noticed by now that watch jewels have different shapes for their different uses. A curved jewel is commonly used for balance pivots, escape wheel pivots and pallet arbor pivots, although a flat, friction-type balance hole jewel may also be used. (See Section 333 in Lesson 14.)

The curved surface was designed to aid in oiling because oil (like other liquids) has a tendency to flow into a narrow space. A simple experiment will show you how this occurs. Take two pieces of flat glass and place two edges together but separate the opposite edges slightly. If you now insert a little oil between them, it will tend to run to where the edges come together. This action or physical phenomenon is called "capillary attraction" and is the means by which oil is held around the pivot end until the oil evaporates (about one year under normal conditions).

If the balance hole jewel and cap jewel are set too far apart, the capillary attraction is reduced and the oil is liable to be drawn away. Hence, it is important to adjust this space between the two stones so the bubble of oil can properly form around the pivot. The customary clearance is about 0.02mm (2/100). You were instructed in Lesson 10 on the method of oiling in which you insert a drop of oil in the oil cup of the hole jewel and force it down with a needle.

When the balance hole jewel is flat, some watchmakers apply a drop of oil to the cap jewel before it is screwed into place. (Some types have a groove to show the extent of the area to carry the oil, but if not, the oil is limited to a similar sized area.) After the balance jewel is in place, a drop of oil is applied as usual to the oil cup.

The types of balance hole and cap jewels and settings for American and Swiss watches described in this lesson have been in use for many years and are still in use. However, as was true for train jewels, it is not always possible to get replacement parts for the older watches whose manufacturer is out of business.

Of the different shapes of roller jewels illustrated in this lesson, only the D-shaped jewel is now in common use. In some modern Swiss watches, the roller jewel is friction fit in the roller.

## KEY POINTS OF LESSON ASSIGNMENTS 43, 44, 45, 46:

- The difference between straight and olive hole balance jewels.
- The proper amount of sideshake for balance pivots.
- How to remove and replace the balance jewel assembly.
- How to order factory set balance and cap jewels.
- Balance jewel assemblies in Swiss watches.
- The purpose of the roller jewel.
- The different shapes of roller jewels.
- The different types of rollers.
- How to determine the proper size roller jewel to use.
- How to set a roller jewel.

ASSIGNMENT NO. 43: Study Sections 305 through 311.

Study Questions:

1. What is the difference between straight and olive hole balance jewels?
2. What is the relation of the balance and cap jewels to the pivots?
3. How much side shake is correct for balance pivots?
4. How is the balance assembly taken apart?
5. What information is needed to order a factory balance jewel?

Supplementary Information:

Section 307: The type jewel settings illustrated in Figures 13-5 and 13-6 are still in use on many models of American watches. Replacement parts are usually available.

Recommended Practice:

Remove the balance, cap and hole jewels from an American watch, preferably large size. Clean, examine and replace.

ASSIGNMENT NO. 44: Study Sections 312 through 313.

What is the difference between Swiss and American balance jewel assemblies?

Supplementary Information:

Section 312: This type of jewel and setting is still in common use. The cap jewel and setting can usually be replaced, except in older models. The balance hole jewel is a burnished-in type. You can replace it with a friction jewel set into the balance bridge.

Section 313: This type of setting is in common use. The balance hole jewel is a friction jewel set in a friction bushing. Equally common is a friction jewel set directly into the bridge without use of a bushing.

Recommended Practice:

Remove, examine, clean and replace the balance jewel assembly in a Swiss watch.

ASSIGNMENT NO. 45: Study Sections 314 through 316.

1. What stock jewel assortments are recommended?
2. How should small and delicate parts be wrapped for shipment?
3. How do the illustrated Hamilton and Illinois balance assemblies differ from other American assemblies?

Supplementary Information:

Section 315: This type of assembly is still used by the Hamilton Watch Company. It is generally possible to get replacement parts regardless of the age of the watch.

ASSIGNMENT NO. 46: Study Sections 317 through 325.

1. What is the purpose of the roller jewel?
2. What are the different shapes of roller jewels?
3. What are the types of roller tables?
4. Is the roller jewel set in the impulse roller or the safety roller?
5. How are roller jewels gauged?
6. What clearance is allowed between the roller and fork slot?
7. What preparations are made before setting a roller jewel?
8. What is the procedure for setting the roller jewel?
9. How is the roller jewel straightened, if set awry?
10. What is the correct length of the roller jewel?

Recommended Practice:

1. Make the tool illustrated in Figure 13-20.
2. Make the tool illustrated in Figures 13-24-1 and 13-24-2.
3. Remove the roller jewel from a practice watch. Clean the hole and the roller jewel and prepare the cement. Then replace the roller jewel. Be sure the roller jewel is set straight and cemented properly so it will not work loose. Clean off any excess cement from the roller jewel and roller table.

REQUIREMENT:

- ▶ Answer all Test Questions for Lesson 13 and return for grading.

# MASTER WATCHMAKING

A Modern, Complete, Practical Course

CHICAGO SCHOOL OF WATCHMAKING

Founded 1908 by Thomas B. Sweazey

Lesson 13

Sections  
305 to 325

## FACTORY BALANCE HOLE JEWELS AND ROLLER JEWELS

### SEC. 305—Olive Hole Jewels

The train jewels shown in the previous lessons had holes through them, the walls of which were straight. In balance hole jewels, there are two types of holes; one type has straight walls

#### STRAIGHT HOLE

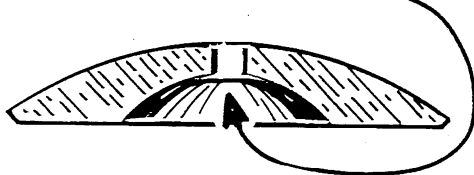

Fig. 13-1

as in the train jewels, figure 13-1, while the other has curved walls and is called an olive hole jewel, figure 13-2. The olive hole gives a smaller bearing surface without sacrificing

#### OLIVE HOLE

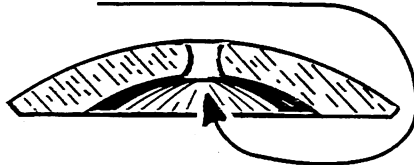

Fig. 13-2

strength and there is less adhesion of oil between the jewel hole and the pivot.

### SEC. 306—Balance and Cap Jewel Assemblies

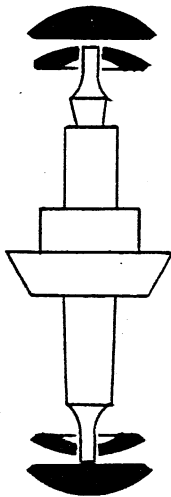

Fig. 13-3

Balance hole jewels are used in connection with cap jewels as bearings for pivots with conical shaped shoulders such as are found on the balance staff. Figure 13-3 is a drawing of cone pivots. In the lesson on train jewels you learned that the side and shoulder of the square shoulder pivot came in contact with the jewel. With a conical pivot, the cone is never in contact with the jewel. The bearing surfaces are at the end and side.

Balance hole jewels are used as bearings for all conical pivots.

The name "balance hole jewel" applies to these jewels when they are used as bearings for the balance staff. However, the same type of jewel assembly is used in watches such as railroad



Fig. 13-4

#### CAP JEWEL

watches where cap jewels are used on pallet and escape wheel assemblies.

The cap jewel, figure 13-4, known also as the end stone, differs from either the balance hole or train jewel in that it has no hole through it but is a plain, highly polished surface, which acts as a bearing for the end of the pivot. The pivot projects through the balance hole jewel and the only part of the pivot that comes in contact with the cap jewel is the end. The cap jewels, one of which is located at each end of the balance staff, determine the amount of end-shake for that particular balance staff.

### SEC. 307—Relation of Balance and Cap Jewels to Pivots

In figure 13-5 is shown the relation of the balance hole jewel D, balance cap jewel C, and the balance pivot. Here you can see that the pivot is held in its central position by the hole in the balance hole jewel and that it is kept from extending too far through that jewel by the cap jewel. In this assembly, each jewel is burnished in a setting and the two settings placed in one opening, the two lower jewels or foot jewels in the pillar plate and the upper jewels or cock jewels in the balance cock. The balance jewel assembly in American watches usually is a setting with a shoulder as shown in figure 13-6. The setting for the cap jewel, figure 13-6, generally has counterbored openings for the heads of the jewel screws. Figure 13-6 also shows the position that they occupy when fitted to the balance cock, C representing balance hole jewel in its setting, B the cap

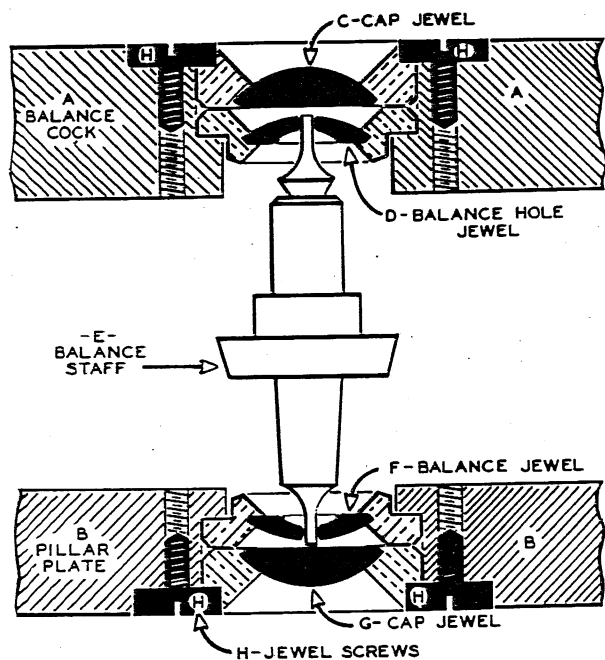

Fig. 13-5

jewel in its setting, D the jewel screws, and A a section of the balance cock.

### SEC. 308—Chart to Determine Proper Sideshake

Measure balance pivot with your micrometer and use the following chart to obtain the proper freedom or sideshake:

Pivot Measures in 100th of a mm	Use Jewel with Hole
.05	.06
.06	.07
.07	.08
.08	.09
.09	.10
.10	.11
.11	.12
.12	.13
.13	.14
.14	.15

Always test the jewel on pivot before replacing. Jewel holes may vary in size slightly. If a properly set balance jewel is placed over a correctly shaped balance pivot, the pivot should go through easily and extend through the jewel about the same distance as its own diameter. Should the pivot not extend through, it is liable to bind when the movement is in such a position that the pivot is running on the cap jewel.

### SEC. 309—Removing Balance Jewel Assembly

The following procedure is used to remove American balance jewel assembly held in place by jewel screws:

1. Remove jewel screws.

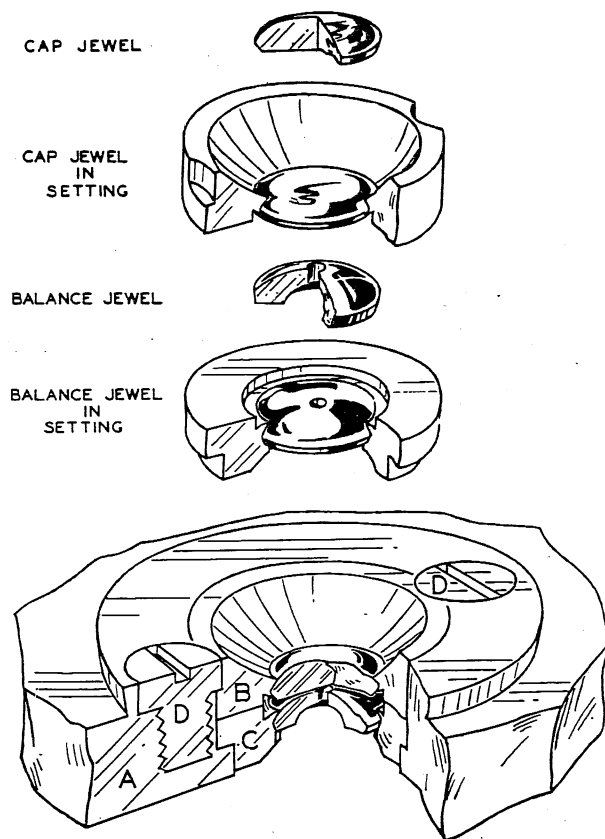

A-BALANCE COCK  
B-CAP JEWEL IN SETTING  
C-BALANCE JEWEL IN SETTING  
D-JEWEL SCREWS

Fig. 13-6

2. Place cock or pillar plate over large hole in bench block.
3. Select proper size jewel pushers and force balance and cap jewel out.
4. Separate balance jewel from cap jewel. With a sharp knife, cut off the end of a piece of pithwood to get a clean, flat surface and with this wipe off any dirt or oil that may be on the faces of the two jewels. When a watch has not been cleaned for a long time or when a poor grade of oil has been used, the surface of the jewels may be covered with gummed or dried oil which the pithwood will not remove easily. In such instances, scrape clean the face of the jewels with the end of a piece of pegwood cut to a chisel shape, and then clean with cleaning solution. Examine each jewel separately using a double eye glass to determine if they are cracked or broken, and whether or not the balance hole jewel is chipped around the hole. If cracked, broken or chipped, it should be replaced with a new jewel.

Sometimes the cap jewel may be found with a slight "pit" in the center of its flat surface where it has been in contact with the pivot.

If the cap jewel is cracked or "pitted", it also should be replaced.

Having examined the jewels to see that they are perfect, cleaned the surfaces and pegged out the hole in the balance hole jewel, you are now ready to replace them in the balance cock, but before doing so, be sure to test the balance hole jewel on the balance pivot to see that it fits correctly.

The main reason we insist that students practice upon better grades of watches, and those which have not been worked upon by incompetent workmen, is so that they may be able to acquaint themselves with the correct relations and fittings of the associated parts. If, at this time, you are working upon a watch that is in first class condition, you can obtain a very good idea of the proper relation of the balance hole jewels and the pivots by testing each hole jewel on the proper pivot.

### SEC. 310—Replacing Balance and Cap Jewel Assembly

Your first step in replacing the jewels will be to insert the balance hole jewel in the opening in the balance cock and to press it down against the seat, using a jewel pusher. Having done this, press the cap jewel in place using care to see that the counterbores match on the jewels and balance cock. Press the cap jewel down firmly against the balance hole jewel and if it is the correct size, the flat surface of the cap jewel setting will be flush with the top of the opening in the balance cock. Insert the balance jewel screws and turn them down until tight. Be very careful and avoid getting any scratches or marks on the cap jewel setting. As you will observe, this setting is stripped and burnished on the top to a high polish. You should endeavor at all times to protect this fine finish.

Having replaced the jewels, you should now proceed to assemble the balance, making certain that there is the proper amount of endshake and that there is no noticeable sideshake on the balance staff.

In fitting a new balance hole jewel, try the pivot to see that the hole is of proper size and compare the shoulder height of the setting with the old one. If this shoulder is not the same as the old one, it will make a difference in the endshake. The new setting must be of the right diameter to insure its being neither too tight nor too loose. If the old cap jewel setting was of the right thickness, the new one should have the same measurements. A variation in this

dimension will make no difference in endshake as long as it is pressed down firmly against the balance hole jewel setting, but if it is a flat setting, it will make a difference in appearance as the top surface should be flush with the balance cock. Should the countersinking at the end of the cap jewel setting be too deep, the balance screw heads may not hold it firmly in place and this loosening of the setting will cause trouble in timing or rating or might even stop the watch under certain conditions.

### SEC. 311—Ordering Factory Jewels

To order a balance hole jewel from a material house, it is only necessary to remove both settings, measure the pivot with micrometer, and select or order a complete new jewel and setting, allowing the difference between hole and pivot size as listed in Section 308.

Example:

Pivot measure .11 mm

1-12s Elgin upper balance jewel hole .12

1-12s Elgin lower balance jewel hole .12

To replace cap simply select or order:

1-12s Elgin upper cap jewel

1-12s Elgin lower cap jewel

Always specify whether upper or lower balance or cap jewel when reordering. Lower jewels may not be of the same dimensions as the upper. Compare shoulders and thickness of settings.

### SEC. 312—Balance Jewels in Swiss Watches

As you have already learned, the American manufacturers set their balance jewels in separate settings which fit openings in either the balance cock or pillar plate. In some Swiss watches, however, a slightly different method is used. The upper cap jewel setting is held in place by two jewel screws inserted from the *lower* side of the balance cock, extending through it and threaded

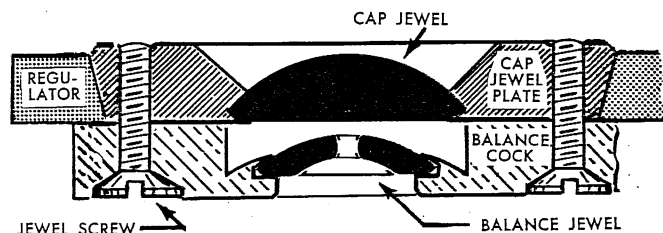

Fig. 13-7A

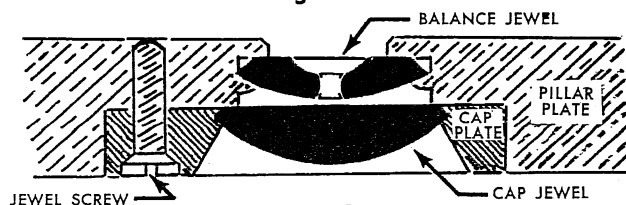

Fig. 13-7B



into the cap jewel plate. (Figure 13-7A) The lower cap jewel setting is held in place by just *one* jewel screw inserted through the cap jewel plate into the pillar plate. (Figure 13-7B) The balance jewels are burnished directly into the balance cock and pillar plate.

To replace the old jewels, force them out. Open the bezel with bezel opener. Select balance jewel of correct diameter and hole size. Replace and burnish. (Similar to Sec. 301, Lesson 12.) However, it is more practical nowadays to replace this burnished type with friction jewels.

The inverted position of the upper jewel screws sometimes causes confusion in reassembly for those accustomed to top side replacement as done on American movements. You can avoid a tendency to set these jewel screws in from the top by reassembly in this way: First, lay down the cap jewel plate upside down. Place the regulator over the cap. (The lower edge of the cap jewel plate is beveled to match the inside of the regulator.) Turn the balance cock upside down also and set it so the two screw holes are directly over the holes in the cap jewel plate. Finally, insert the screws from this side.

When the regulator is in place and the cap jewel plate tightened by the jewel screws, the regulator will be held securely because the overlapping top edge of the cap jewel plate acts as a wedge to hold the regulator.

### SEC. 313—Swiss Friction Settings

Figure 13-8 illustrates the modern balance hole and cap jewel assembly used in Swiss watches. Here the cap jewel is held in place in the cap jewel plate by friction and the plate is held in place by two jewel screws set in from the under side. The balance hole jewel is held in the setting by friction and the setting is in turn a friction setting set in the cock or pillar plate. Replacing this type of jewel comes under friction jewelling.

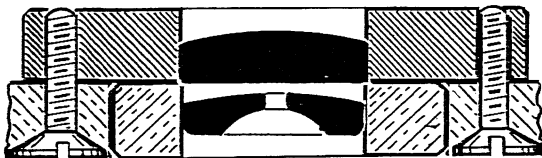

Fig. 13-8

You may find old Swiss watches in which the cap jewel is merely set under the cap without being held in place by the bezel. This naturally does not give the proper distance between the cap jewel and the balance hole jewel since the cap jewel then sets directly on the balance hole jewel and the oil has a tendency to spread away from the pivots.

### SEC. 314—Balance and Cap Jewel Assortments

Most watchmakers carry assortments of balance hole and cap jewels to fit the more common American watches. In the better arranged assortments of balance hole jewels in settings each bottle or capsule contains jewels for a specified size of watch and with the assortment is an index showing these makes and sizes. Thus if you wish to replace the upper balance hole jewel of a 16 size Waltham watch, find on the index card the number of the bottle containing the upper balance hole jewel for a 16s Waltham movement. As explained in Sec. 308, if the pivot measures .10 mm, you should select a jewel with a .11 mm hole in order to get the proper amount of sideshake. The jewel selected will not necessarily fit exactly, and it must be tried on the pivot before placing in the watch.

It is not necessary to carry a large assortment of cap jewels as one bottle for each size is sufficient. Nor is it necessary to subdivide the sizes as one cap jewel will suffice regardless of the size of the pivot, provided the setting is of the correct diameter and thickness.

When ordering a single balance hole jewel, state the make and size of watch for which it is intended, whether a cock or foot jewel, and the size hole desired. Send in the old jewel with your order. If not sure of the hole size, send in the balance also. In shipping a balance or any small part of a watch by mail, to protect it in transit, always wrap it in watch paper and place it in a small metal box or container. If a cap jewel is ordered, give make and size of movement and whether cock or foot jewel and send in old jewel setting as a sample.

### SEC. 315—Hamilton Balance Jewel Assembly

Figure 13-9 is a cross section of a Hamilton style balance jewel assembly. The balance jewel setting, which is a friction setting, holds the cap jewel in place. Remove and replace with staking tool or jewel pusher.

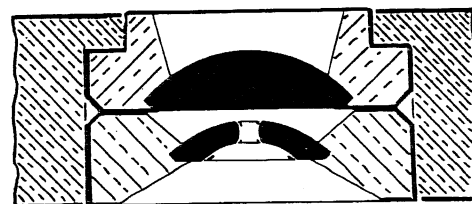

Fig. 13-9

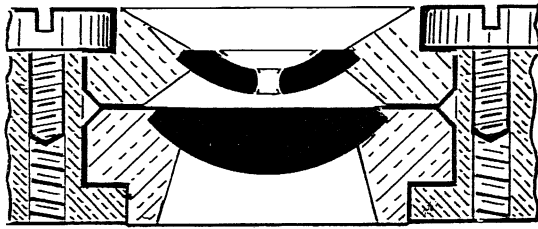

Fig. 13-10

**SEC. 316—Illinois Balance Jewel Assembly**

Figure 13-10 illustrates a type of balance and cap jewel setting found in some models of watches, namely, Illinois. The settings are removed and replaced by removing the jewel screws and removing the settings from the under side of the balance cock or pillar plate.

**SEC. 317—Purpose of the Roller Jewel**

The impulse from the fork is conveyed by means of the jewel pin, or roller jewel as it is more commonly known, and causes the balance to turn. It is sometimes referred to as the impulse pin. This pin or jewel is set in the roller table by means of shellac and the roller is driven on the lower tapered end of the balance staff friction tight. The roller table is made of steel or of softer metals such as nickel, oreide, etc. In some models of watches using a composition roller, the roller jewel is forced into place without the use of shellac or cement.

Roller jewels are made of garnet, sapphire, or ruby. Garnet roller jewels are softer and are broken more easily than ruby or sapphire jewels; the difference in cost is so slight that it is advisable to use the better quality of roller jewels for your repairs.

**SEC. 318—Shapes of Roller Jewels**

There are several different shapes of roller jewels. The so-called half round is more the shape of a D, as shown in figure 13-11. This type of roller jewel is used in the majority of modern watches. Occa-

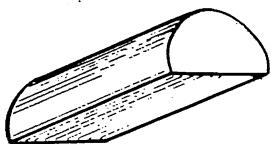

HALF ROUND OR -D- SHAPE

Fig. 13-11

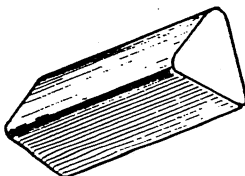

TRIANGULAR

Fig. 13-12

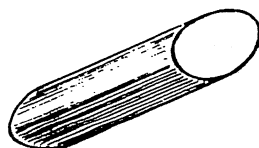

OVAL

Fig. 13-13

sionally you may find watches with triangular shaped roller jewels as shown in figure 13-12. These are used in some of the higher grades of Swiss watches. Another type is the oval roller jewel illustrated in figure 13-13.

**SEC. 319—Types of Roller Tables**

There are three types of rollers or roller tables used in modern watches. Most of the older models of watches are equipped with the single roller as illustrated in figure 13-14, in front of which has been milled out a small section called

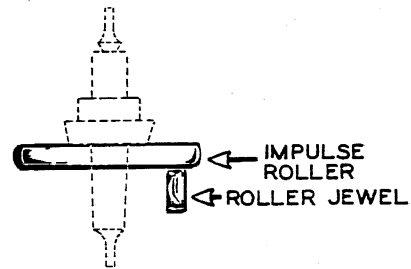

SINGLE ROLLER

Fig. 13-14

the passing crescent. Another type, the two piece double roller, consists of two separate rollers. The larger one carries the roller jewel and is known as the impulse roller, while the smaller one contains the passing crescent and is called the safety or guard roller. The balance staff used with this type of double roller has two shoulders and each roller is fitted to its respective shoulder. In figure 13-15 the larger of the two rollers contains the roller jewel while the guard roller, which is below, contains the passing crescent. While the impulse roller is usually thought of as being circular in form, any other shape will perform as well provided it fulfills the function

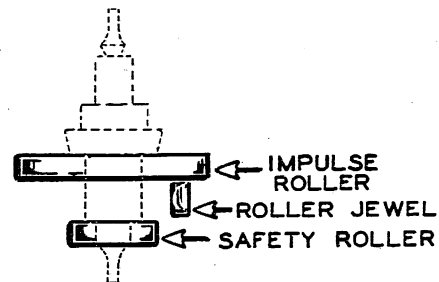

TWO PIECE DOUBLE ROLLER

Fig. 13-15

of carrying the roller jewel at the required distance from the balance staff and does not throw the balance out of poise. The most common form of double roller is called the combination roller, figure 13-16. Here the impulse roller

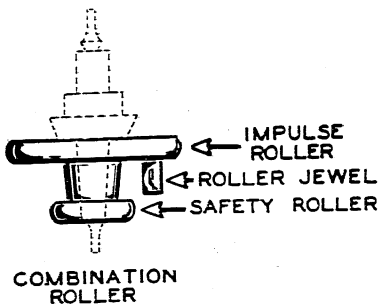

Fig. 13-16

and safety roller are permanently connected by means of a tube or pipe. They are held in place on the balance staff by friction and the staff requires only one seat similar to the one used with a single roller.

**SEC. 320—Gauging Roller Jewels**

Roller jewels are gauged in hundredths of a millimeter. Thus a roller jewel size 30 measures 30/100 mm across its greatest diameter.

The freedom or "shake" between the roller jewel and the slot in the fork should be approximately .015 to .02 mm. Formerly, it was customary to gauge the roller jewel by holding it with the tweezers and trying the freedom or shake by moving it back and forth in the slot of the fork. Many a jewel has been snapped out of the tweezers while doing this. A roller jewel gauge used in combination with an assortment of roller jewels in metric sizes has done away with this troublesome test and has made the selecting of the roller jewel a comparatively simple problem for any watchmaker to master. Figure 13-17 illustrates a roller jewel gauge which consists of a series of leaves somewhat on the order of a feeler gauge. Each leaf or feeler is stamped with a number which corresponds to the number of sizes used in the roller jewel

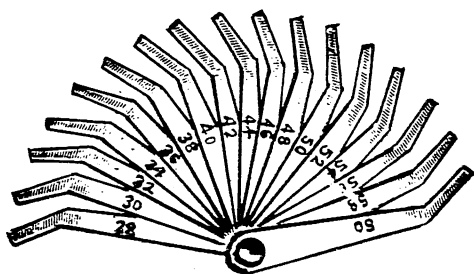

Fig. 13-17

assortment. With this instrument you can readily gauge the width of the slot in the fork, and allowing .01 to .02 mm for freedom or shake, arrive at the correct size of jewel to select from an assortment. It is not necessary to take the watch apart to do this; merely remove the bal-

ance cock and balance and select the gauge, the tip of which fits the slot in the fork without shake but yet is not tight enough to stick, figure 13-18. With this gauge it is not necessary to figure the amount of sideshake on the jewel; merely select a jewel approximately .02 mm smaller than the number on the particular

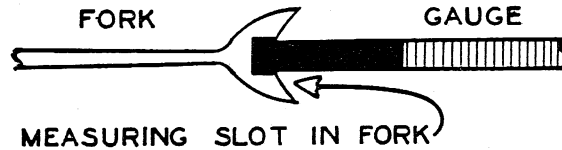

Fig. 13-18

gauge that fits the slot. Example: Gauge stamped 36, select jewel 34. It is advisable to try jewel in fork slot before setting. The following chart gives the most common sizes and their comparative sizes on the gauge:

Slot in fork measures	Use roller jewel
28	26
30	28
32	30
34	32
36	34
38	36
40	38
42	40
44	42
46	44
48	46
50	48

**SEC. 321—Preparation For Setting Roller Jewel**

A broken roller jewel is a frequent cause of stoppage in a watch and it is an easy matter for the master watchmaker to locate this trouble. Suppose a customer brings a watch to you for repairs. In your examination of the balance staff give the watch a slight circular twist to make the balance swing back and forth. Should you find that while the balance oscillates freely the fork does not move, you can feel justified in making an estimate for a new roller jewel. The jewel usually breaks flush with the roller table and it is an easy matter to press the remaining piece of jewel out of the roller with a pointed steel wire or needle.

Before replacing the new roller jewel, remove all old cement with a chisel-shaped piece of brass wire. Brass is used because it will not mar the surface of the roller yet it is harder than the cement. Figure 13-19 illustrates a tool which can be made from a piece of brass or nickel wire about 2 mm in diameter and approximately 35 mm long. Figure 13-20 is an enlarged view of this tool.

The hole into which the jewel is to be set should be cleaned with a piece of pegwood

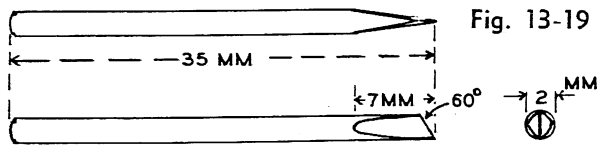

Fig. 13-19



Fig. 13-20

sharpened to a long point. Twist the pegwood, which has been dipped in alcohol, around in the hole until all of the old cement has been removed. Select a jewel to fit the slot in the fork, and see that it is absolutely clean. Holding the jewel in a pair of tweezers, dip it in alcohol and press the jewel into pithwood. It is essential that the hole in the roller and the jewel be perfectly clean in order that the jewel can be set securely. The main cause of loose roller jewels is that the hole and jewel were not absolutely clean or the cement had been overheated.

### SEC. 322—Preparing Cement

Practically all roller jewels are held in place by means of cement. Once in awhile you may find one set in a composition roller without cement. These jewels are pressed into position. Liquid cement is not recommended for setting roller jewels. You will find shredded shellac will serve the purpose better and if prepared properly, is more easily handled. Prepare as follows: Heat the end of a stick of lathe cement or shellac in the flame of an alcohol lamp, turning it over and over until the end becomes very soft. Be careful not to burn it. Grasp a small portion of the warmed cement with a pair of tweezers and pull it out into a string of cement. If you desire a thin string, pull it out rapidly and for a thicker string, pull it out more slowly. It is wise to prepare a number of these threads of shellac for future use. See figure 13-21.

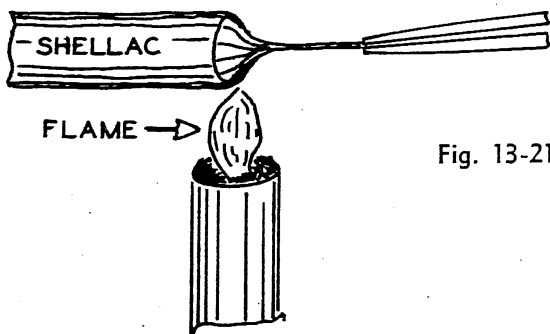

Fig. 13-21

### SEC. 323—Setting the Roller Jewel

There are a number of tools on the market designed for use in setting a roller jewel. Some of these will work very well on one type of roller but not on another, or perhaps they will work all right on large sizes of watches but are not very satisfactory for bracelet watches. With other types it is necessary to remove the roller from the staff.

The combination tool shown in figure 13-22 will be found satisfactory for the average watch and can be used for either single or double rollers without removing the roller from the staff. The combination tool holds the roller table on the edge and conveys the heat applied from the alcohol lamp to the table and jewel while setting or adjusting.

To set a roller jewel, open the jaws of the tool, figure 13-22, by pressing the button at A and catch the roller between the grooved jaws B with the balance above the flat faces of the jaws. The hole which receives the roller jewel should be centered between the jaws and toward the open portion of the jaws. In replacing the jewel it will be necessary to turn the combination tool over. Apply heat to the extreme end of arm C with the flame of your alcohol lamp, and when hot enough to melt the cement, insert the end of a thread of cement into the hole in the roller until it is completely filled. After pulling the rest of the cement away, apply heat to arm C again until cement flows evenly in hole. While the cement is still warm, insert the previously selected and cleaned roller jewel into the hole with the tweezers, pressing it through the warm cement until the jewel is flush with the top of the roller table. Warm again and touch the end of cement

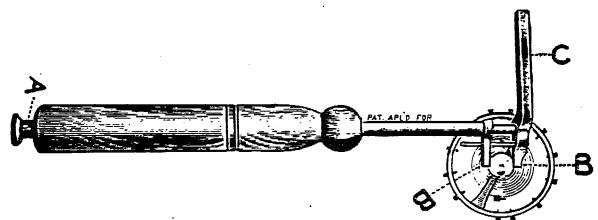

Fig. 13-22

thread to the top of the jewel until it melts over the end of jewel and roller table. Keeping the roller warm, grasp the roller jewel with the tweezers and move it up and down in order that the cement will completely surround the jewel in the hole. Remove and let cool and then with the tool illustrated in figure 13-19, remove all surplus cement from the face and sides of the jewel and also from roller table.

**SEC. 324—Straightening Roller Jewel**

The roller jewel must be so adjusted that the flat side forms a right angle with an imaginary line drawn from the center of the balance staff through the center of the roller jewel. If after setting the jewel you find the face at an incorrect angle, it can be adjusted by grasping the jewel with the tweezers and twisting it around to the angle desired, figure 13-23. In this case, the tweezers must be moved in the direction of arrow C to line A-B. Do not try to move jewel without preheating the roller table.

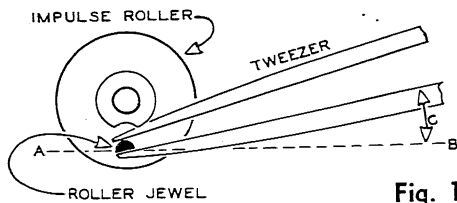

Fig. 13-23

The jewel, when viewed from the front and side, should form a right angle with the roller table. To straighten roller jewel file to the shape shown in figure 13-24-1 & 2 a piece of brass wire about 2 mm in diameter and mount

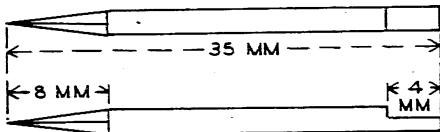

Fig. 13-24-1



Fig. 13-24-2

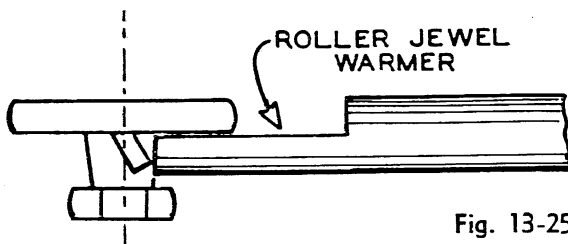

Fig. 13-25

it in a small handle. In using this handy tool, the end is heated with the alcohol lamp and pressed against the jewel as shown in figures 13-25 and 13-26. The heat applied need only be sufficient to soften the cement, after which it is an easy matter to press the jewel into an upright position. At first you may have a tendency to press too hard, pushing the jewel until it stands in the opposite direction. Repeat the operation until jewel is correctly positioned. After a little practice you will find the correct amount of pressure to apply. Care must be taken in applying heat to the roller in order to avoid burning the cement. When the cement becomes glossy and will spread, it will be of

the correct temperature. Never heat the roller enough to cause it to discolor.

**SEC. 325—Correct Length of Roller Jewel**

The length of the roller jewel must be taken into consideration when selecting one for either the double or single roller. For a double roller, the jewel must be long enough to extend through the fork yet not long enough to come in contact with the guard dart. This can be judged by sighting across the guard roller. Figure 13-27 shows the length of the roller jewel. If the roller jewel extends down far enough to come in contact with the guard dart, the watch will stop. The roller jewel in a single roller must be long enough to extend through

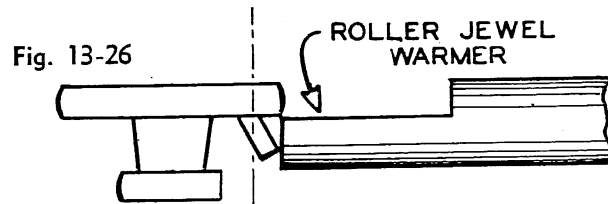

Fig. 13-26

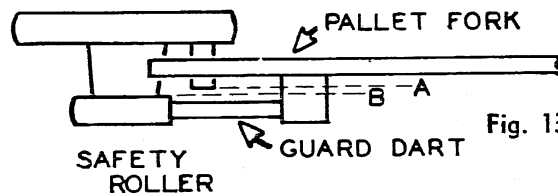

Fig. 13-27

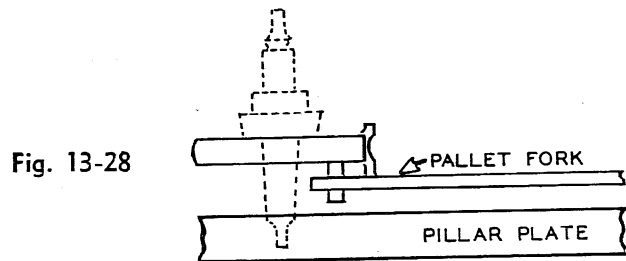

Fig. 13-28

the fork, figure 13-28, but not long enough to rub on the balance jewel setting or plate.

Having set the jewel as directed in Section 323, its face square with the fork and perpendicular to the impulse roller, take hold of it with your tweezers while holding the balance in watch paper. Use your double loupe in examining the jewel to see that it is solidly set. Examine the edge of the roller table and the roller jewel to see if there is any cement other than that surrounding the jewel in the hole. If there is, scrape off all excess using the chisel-shaped brass wire. Examine and clean the passing crescent on all single rollers. Clean and brush carefully with soft brush. **DO NOT USE OIL ON THE ROLLER JEWEL.**

## CHECK YOURSELF

Progress Check I3A

A Self Test Review of Lesson 13

After you have studied Sections 285 through 302, see if you can answer these questions without looking back. **DO NOT SEND YOUR ANSWERS TO THE SCHOOL.** You'll find answers at the end of this test. If you miss any questions, review the section on which the statement is based.

DIRECTIONS: Complete the following statements by writing the correct word or words in the blank spaces.	Section Ref.
1. Two types of balance hole jewels are _____ and _____.	305
2. Balance hole jewels used with cap jewels are used as bearings for _____ pivots.	306
3. Jewels without holes, which serve as bearings for ends of pivots, are known as _____ jewels or _____.	306
4. To provide proper sideshake, the difference between the size of the balance pivot and the side of the balance hole jewel should be _____ mm.	308
5. In replacing the balance and cap jewel assembly, a good workman is careful to protect the _____.	310
6. In fitting a new balance hole jewel, three points to check are the size of the _____, the diameter of the _____, and the height of the _____ on the setting.	310
7. When ordering balance or cap jewels, you must specify _____ or _____ because the dimensions may vary.	311
8. In many Swiss watches, the jewel screws are screwed in from the _____ side of the balance cock.	312
9. The modern Swiss balance hole and cap jewel are held in place by _____.	313
10. To avoid having to order jewels for each repair, most watchmakers will stock _____ of _____.	314
11. In the Hamilton balance jewel assembly shown in the lesson, the _____ setting holds the _____ in place.	315
12. After a cap and balance jewel assembly has been taken out, any _____ should be removed from the surfaces of the jewels.	309
13. Cap jewels which are pitted should be _____.	309

CHECK YOURSELF

Progress Check 13B

A Self Test Review of Lesson 13

After you have studied Sections 317 through 325, see if you can answer these questions without looking back. DO NOT SEND YOUR ANSWERS TO THE SCHOOL. You'll find answers upside down at the end of the test. If you miss any questions, review the section on which the statement is based.

DIRECTIONS: Complete the following statements by writing the correct word or words in the blank spaces.	Section Ref.
1. The _____ transfers the impulse from the fork to the balance wheel.	317
2. The roller jewel is usually held in place by _____ but a few types are _____.	317
3. Of the various shapes of roller jewels, the _____ shape is most common.	318
4. The three types of roller tables are: a. _____ b. _____ c. _____	319
5. Roller jewels are gauged in _____ of a _____.	320
6. Sideshake between the roller jewel and the slot in the fork is about _____ mm.	320
7. A quick means for determining the proper roller jewel size is to use a _____.	320
8. When setting a new roller jewel, the first step is to remove all traces of old _____.	321
9. The preferred type of cement for setting roller jewels is _____.	322
10. The roller jewel must be set while the cement is _____.	323
11. To straighten an out of line roller jewel, it is essential to first _____.	324
12. The roller jewel in a double roller table must clear the _____.	325

=====

ANSWERS TO  
PROGRESS CHECK 13A:

- 1. straight
- 2. conical
- 3. cap
- 4. 1/100
- 5. finish
- 6. hole
- 7. upper
- 8. under
- 9. friction
- 10. assortments
- 11. balance jewel
- 12. gummy or dried oil
- 13. replaced

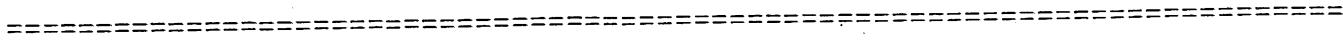

ANSWERS TO  
PROGRESS CHECK 13B:

- 1. roller jewel
- 2. shellac
- 3. D or half round
- 4. single roller
- 5. combination roller
- 6. .02 (2/100)
- 7. roller jewel gauge
- 8. cement
- 9. shredded shellac
- 10. warm
- 11. soften the cement
- 12. guard dart
- 13. two piece double roller
- 14. hundredths
- 15. millimeter



HOW TO REMOVE AND REPLACE A "D" SHAPE ROLLER JEWEL IN A SINGLE ROLLER.

Tools, Equipment and Supplies:

- |                    |                         |                    |
|--------------------|-------------------------|--------------------|
| Combination Tool   | Chisel-shape Brass Wire | Roller Jewel Gauge |
| Hairspring Remover | Roller Jewel Warmer     | Tweezers           |
| Alcohol Lamp       | Jewel Cement (Shellac)  |                    |

PROCEDURE:

REFERENCE:

- |   |                       |
|---|-----------------------|
| 1. Remove balance assembly from movement.   | Lessons 5 & 8         |
| 2. Remove hairspring. (Optional)  | Lesson 15<br>Sec. 352 |
| 3. Grip roller in jaws of combination tool. Heat tool over alcohol lamp. Remove roller jewel when cement softens. | Fig. 13-22            |
| 4. Remove balance assembly from combination tool and allow to cool.   | Sec. 323              |
| 5. Clean roller of all cement and foreign matter with chisel-shape brass wire.                                    | Sec. 321              |
| 6. Select replacement jewel.  | Sec. 320              |
| 7. Grip roller in jaws of combination tool, reheat, and apply cement to jewel hole.                               | Sec. 323              |
| AN ALTERNATE METHOD: Insert roller jewel in roller before applying cement.  |                       |
| 8. While cement is still soft, set roller jewel in roller.  | Sec. 323              |
| 9. Reheat and move jewel up and down in hole to surround the jewel with cement.                                   | Sec. 323              |
| 10. Examine closely to see that jewel is well cemented.   |                       |
| 11. If jewel is not firmly set and upright, reheat and straighten.  | Sec. 324              |
| 12. Remove from combination tool, let cool, and clean off any surplus shellac with the chisel-shape brass wire.   | Sec. 321<br>Sec. 323  |

HOW TO REMOVE AND REPLACE A "D" SHAPE ROLLER JEWEL IN A DOUBLE ROLLER.

Tools, Equipment and Supplies:

Combination Tool  
Hairspring Remover  
Alcohol Lamp

Chisel-shape Brass Wire  
Roller Jewel Warmer  
Jewel Cement (Shellac)

Roller Jewel Gauge  
Tweezers

PROCEDURE:

REFERENCE:

- |   |                      |
|---|----------------------|
| 1. Remove balance assembly from movement.   | Lessons 5 & 8        |
| 2. Remove hairspring. (Optional)  | Sec. 352             |
| 3. Grip roller in jaws of combination tool. Heat tool over alcohol lamp. Remove roller jewel when cement softens. | Fig. 13-22           |
| 4. Remove balance assembly from combination tool and allow to cool.   | Sec. 323             |
| 5. Clean roller of all cement and foreign matter with chisel-shape brass wire.                                    | Sec. 321             |
| 6. Select replacement jewel.  | Sec. 320             |
| 7. Grip roller in jaws of combination tool, reheat, and apply cement to jewel hole.                               | Sec. 323             |
| AN ALTERNATE METHOD: Insert roller jewel in roller before applying cement.  |                      |
| 8. While cement is still soft, set roller jewel in roller.  | Sec. 323             |
| 9. Reheat and move jewel up and down in hole to surround the jewel with cement.                                   | Sec. 323             |
| 10. Adjust roller jewel so as to be just above passing crescent.  | Sec. 325             |
| 11. Examine closely to see that jewel is firmly cemented.   |                      |
| 12. If jewel is not firmly set and upright, reheat and straighten.  | Sec. 324             |
| 13. Remove from combination tool, let cool, and clean off any surplus shellac with the chisel-shape brass wire.   | Sec. 321<br>Sec. 323 |

Test Questions**Master Watchmaking**Lesson No. 13

Name: \_\_\_\_\_

No: \_\_\_\_\_

Date: \_\_\_\_\_

Circle the correct answer (or answers):      SUBJECT: Factory Balance Hole Jewels and Roller Jewels.

1. One of the advantages of the olive hole jewel is that it:

Has a smaller bearing surface

Is cheaper to manufacture

Is less apt to break

Is easier to replace

2. Cap jewels are sometimes known as:

Jewel pins

Impulse jewels

End stones

Center jewels

3. The balance pivot is held in its central position by:

The jewel screws

The cap jewel

The balance cock

The hole in the balance jewel

4. The end shake of the balance staff is determined by:

The size of the hole in the balance jewels

The diameter of the cap jewels

The location of the balance hole jewels

The location of the cap jewels

5. To obtain the proper sideshake or freedom, a balance pivot measuring 10/100th of a millimeter would require a balance jewel with what size hole?

.10 mm

.11 mm

.12 mm

.13 mm

6. When fitting a new balance hole jewel and setting in an American watch you should make sure of at least three things before replacing the setting in the balance cock. Circle the three which are necessary, assuming that the old jewel and setting were correct:

Height of shoulder of setting must be same as old one

Hole must be of proper size

Diameter of setting must be same as old one

Jewel itself must be same diameter as old one

7. Which of the following shape roller jewels are described in this lesson?

Half Round

Triangular

Square

Oval

8. Roller jewels are gauged in:

Hundredths of a millimeter

Tenths of a millimeter

Thousandths of an inch

Sixteenths of a ligne

9. If the slot in the fork measured 40 with a roller jewel gauge, you would select a roller jewel measuring:

36

38

40

42

10. In order to set a roller jewel securely, you must:

Heat cement very hot

Use liquid cement

Be sure jewel fits tightly in hole in roller

Have hole in roller and the jewel absolutely clean

11. With a double roller, the roller jewel must:

Be exactly even with the bottom of the fork

Extend through the fork and just touch the guard dart

Extend about two-thirds of the way through the fork

Extend through the fork but not touch the guard dart

12. After setting the roller jewel, which of the following should be done? (Circle all correct answers)

Oil the roller jewel

Use double loupe and take hold with tweezers to see it is solidly set

See that it is perpendicular to the impulse roller

Examine roller table and jewel to see if there is any excess cement

Detach page or cut along this line and send to the School for grading.

# Student Consultation Sheet

Date \_\_\_\_\_ Student No. \_\_\_\_\_

Lesson No. \_\_\_\_\_

(Use this sheet to ask any questions you may have on the lesson or assignments. Use the left half of the sheet. Number your questions. Your instructor will write the answer opposite your question and return this sheet for your file.)

Name	_____
Address	_____
City	_____
State	_____
Zip Code	_____

Please check ( ) if you have CHANGED YOUR ADDRESS.

Each page or cut on line and use this sheet if you have questions on the course.

ASK YOUR QUESTIONS HERE...

WE'LL ANSWER HERE...

INSTRUCTOR: Return an unused sheet with each used one.

(If necessary, use other side.)