

# KENKOIRE™ MATTRESS

## QUICK REFERENCE SHEET



- Promotes quality sleep for better rest, better health
- The only sleep system with this combination of technologies
- Revolutionary air support suspension
- Nikken Magnetic Technology
- Nikken Rubberthane nodules
- Hypoallergenic bamboo-fiber cover
- Advanced edge support

### KenkoAire Mattress construction

1. Cover
2. Magnet/Rubberthane layer
3. Foam spacer
4. Air chambers (single or pair)
5. Interlocking bolsters
6. Mattress enclosure
7. Air hoses
8. Foundation or platform if desired (not provided)
9. Air pump
10. Hand controls

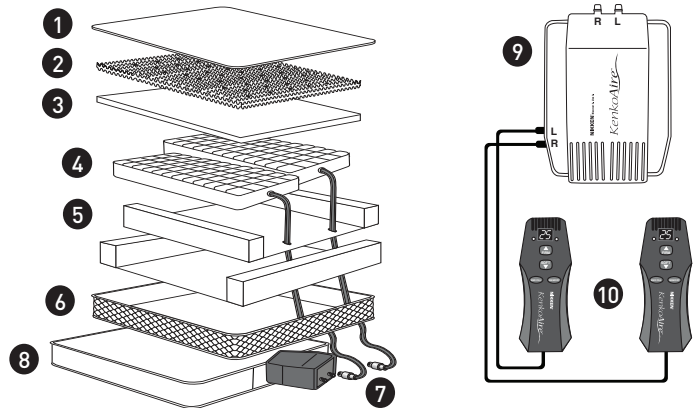

### KENKOIRE MATTRESS FEATURES/BENEFITS:

- **Air support technology**..... Eliminates pressure points, for unparalleled comfort and weight distribution.
- **Adjustable firmness** ..... For selecting the perfect blend of softness and support, every time.
- **Orthopedic support**..... Provides correct spinal alignment for back and neck.
- **Anatomic foam spacer** ..... Based on the grid used in hospitals for correct sleep posture.
- **Double-cell construction** ..... Allows each sleeper independent control of firmness settings.
- **Nikken Rubberthane** ..... Gentle, passive massage effect promotes relaxation.
- **Nikken Magnetic Technology**..... Strategically placed magnets replicate the natural sleep environment.
- **Advanced edge support** ..... Maximizes the usable area for support that extends to edge of mattress.
- **Bamboo-fiber cover** ..... Soft, durable, breathable, naturally antimicrobial.

Nikken sleep technology has received the exclusive endorsement of the World Federation of Chiropractic.



# KENKOIRE™ MATTRESS

## QUICK REFERENCE SHEET

### THE FACTS

- The KenkoAire Mattress combines the best of East and West. It is inspired by traditional Asian sleeping materials, applied to a modern air-flotation system that offers enhanced comfort and selectable firmness.
- The air support technology in this mattress represents a revolution in design. A conventional innerspring mattress can be too hard or too soft. Over time, it develops low spots and eventually sags. Most importantly, it does not give equal support to all parts of the body, which results in uncomfortable pressure points. Kenko air support technology solves all of these problems.
- Because you are resting on a cushion of air, your weight is distributed evenly over the entire surface — eliminating a major cause of back pain.
- Two adjustable, separate air chambers (in most sizes) allow each sleeper to select a degree of firmness that's just right. The settings can be changed at any time, using the digital control. You can vary the degree of firmness for those occasions when you need to ease sore muscles, or to provide added support.
- The KenkoAire Mattress uses single-pole surface magnets to replicate the earth's natural magnetic field. Human beings slept within this field for thousands of years, until modern civilization weakened its influence. Nikken restores this environment with Magnetic Technology.
- Nikken Kenko pillows and comforters complement the mattress, with magnets that complete a magnetic cocoon effect, as well as other complementary technologies, to contribute to better sleep.
- Rubberthane is an exclusive Nikken technology that combines a surface of nodules with specially treated tips to produce a massaging effect that is activated by the sleeper's own natural motion. The result is like a relaxing, gentle massage while you sleep.
- The hypoallergenic cover and materials — including natural bamboo fiber — serve as more than a simple, impermeable barrier like those used in some mattresses to resist allergens. The KenkoAire Mattress features a hypoallergenic surface that discourages the spread of these irritants.
- As many as 100 million people in the United States alone experience sleep problems. Poor sleep can harm your health in many ways: it is known to contribute to stress, fatigue, emotional difficulties and physical problems including weight gain. The Nikken KenkoAire Mattress is a practical, effective way to support your health — as easily as getting a good night's sleep.



### PRODUCT INFORMATION

The KenkoAire may be preordered with receipt of a 10% deposit, for delivery in January 2007.

PREORDER ITEM CODE	DESCRIPTION	SUGGESTED US RETAIL	SUGGESTED CN RETAIL
#8326	KenkoAire™ Mattress - Full	\$3,124.00	\$3,593.00
#8327	KenkoAire™ Mattress - Queen	\$3,436.00	\$3,951.00
#8328	KenkoAire™ Mattress - King	\$3,874.00	\$4,455.00
#8329	KenkoAire™ Mattress - CalKing	\$3,874.00	\$4,455.00

The following item codes apply after January 1, 2007.

ITEM CODE	DESCRIPTION	SUGGESTED US RETAIL	SUGGESTED CN RETAIL
#1070	KenkoAire™ Mattress - Full	\$3,124.00	\$3,593.00
#1071	KenkoAire™ Mattress - Queen	\$3,436.00	\$3,951.00
#1072	KenkoAire™ Mattress - King	\$3,874.00	\$4,455.00
#1073	KenkoAire™ Mattress - CalKing	\$3,874.00	\$4,455.00

#### AVAILABILITY

US: YES CN: YES

#### FEATURED NIKKEN TECHNOLOGY

Air support technology, Nikken Magnetic Technology, Nikken Rubberthane Technology

#### GAUSS RATING

800 per magnet. Full 158 magnets, Queen 196 magnets, King 226 magnets

#### MATERIALS CONTAINED IN PRODUCT

Polyurethane foam, magnetic disks, natural bamboo fiber, cotton

#### CLEANING INSTRUCTIONS

Spot clean only, do not oversaturate. Do not jump or place heavy objects on mattress

#### WARRANTY INFORMATION

20-year limited warranty, covered at 100% for 3 years, prorated

### QUICK SHARING TIP

Adjustable air support technology has been evaluated in scientific tests at a major university and a city hospital. Nearly 90% of study subjects reported better sleep, compared to a conventional bed. **More than 90% said this technology gave them relief from back and body pain.**

**CAUTION:** If you use an electronic medical device such as a pacemaker, or have a magnetically sensitive surgical implant, do not use this product. Women in the first trimester of pregnancy, or anyone who has a health problem should first consult a physician before using this product. Do not place in direct contact with magnetically sensitive items such as watches, audio/video tapes, credit cards, portable electronic equipment, etc.