

## COLOR CODED WIRES ON THE ADP KEYED CONNECTOR

PIN NO.	COLOR	FUNCTION	CONNECTION
6	BLACK	SIGNAL GROUND	TO ENGINE GROUND
8	BROWN	SOLENOID GROUND	TO ENGINE GROUND
3	RED	ADP POWER	TO SWITCHED +12 V
4	VIOLET	SOLENOID POWER	TO FCV ON CONVERTER
9	YELLOW	SOLENOID ACTIVE	TO FCV ON CONVERTER
1	WHITE	IGNITION TACH (RPM) INPUT	TO IGNITION TACH SIGNAL
7	GREEN	EGO SENSOR SIGNAL	TO EGO SENSOR OR SUPPORT MODULE
5	GRAY	OPEN LOOP WITH AIR PUMP "ON" OR AIR PUMP SIGNAL	TO AIR PUMP (See page 6)
2	ORANGE	NONFUNCTIONAL	NO CONNECTION

## TYPICAL ADP FUEL CONTROL PROCESSOR WIRING SCHEMATIC

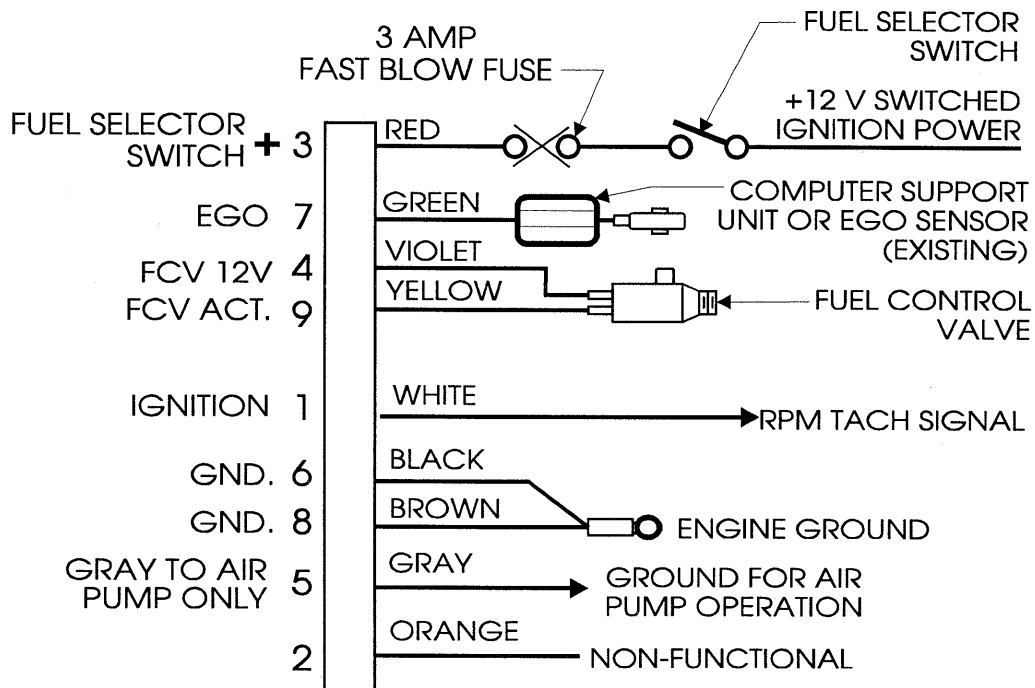

## DUAL FCV WIRING (CNG ONLY)

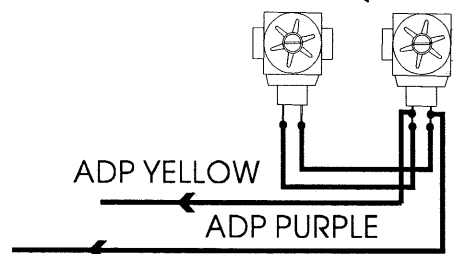

# ELECTRICAL DIAGRAMS ADP TACHOMETER SIGNAL

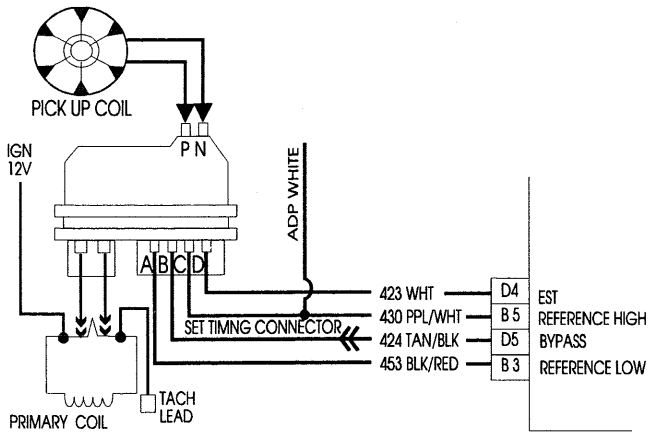

## GENERAL MOTORS

Shown at left is a sample GM ignition circuit. With this ignition circuit the ADP white tachometer wire must be tapped into the #430 purple and white wire **reference high**. Although this is a very typical diagram it is to be used as a **sample only**. Always consult your factory service manuals ignition diagram for this connection, and connect ADP **WHITE** to **reference high**. Always solder this connection. This line is sensitive to electrical noise. Always route the ADP white tachometer wire away from secondary ignitions wires. Reference signal for vehicles with **DIS** is located at coil pack.

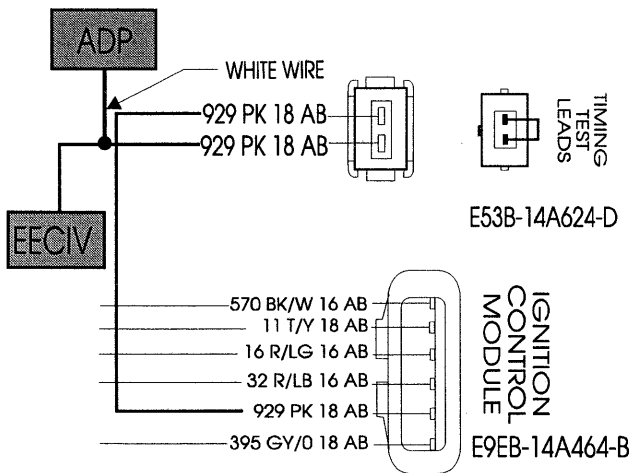

## FORD MOTOR CO.

Shown at left is a typical Ford ignition circuit. Connect the ADP white tachometer wire to the spout connector. Always make this connection on the **EEC** side of the loop. Failure to do this may cause engine to stop when the service technician attempts to set the ignition timing.

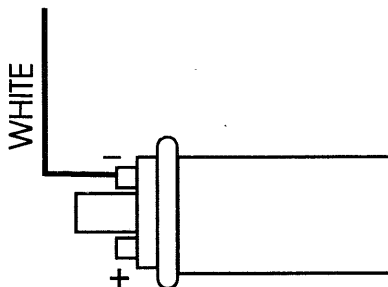

## CHRYSLER

At this time it is recommended that all ADP tachometer connections on Chrysler, and Dodge vehicles will be connected to the secondary ignition coil **negative**.

**FOR VEHICLES WITH STANDARD IGNITION SYSTEMS, FOLLOW CHRYSLER DIAGRAM.**

# AIR DIVERTER CONNECTIONS

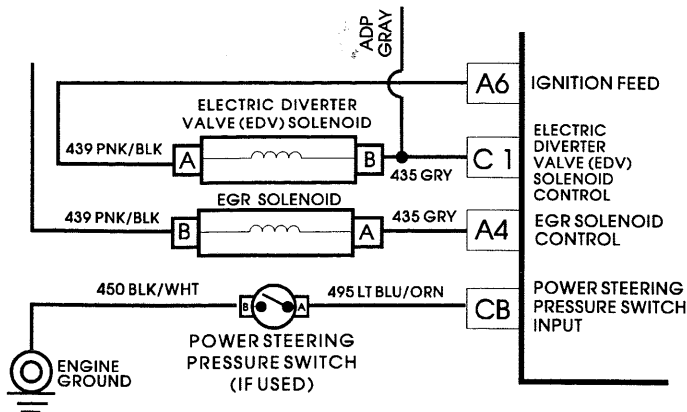

## GENERAL MOTORS

Connect the ADP gray wire to the electric diverter valve (EDV) solenoid ground. This circuit supplies +12 volts, and the ECM shows the solenoid ground on pin C1. Use this diagram as a sample only. Always refer to specific wiring diagrams for the vehicle you are converting. See diagram left.

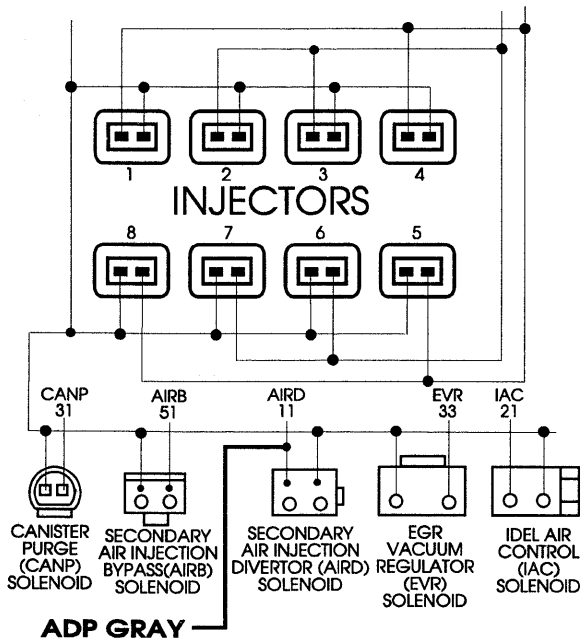

## FORD MOTOR COMPANY

Connect the ADP gray wire to the secondary air injection divertor (AIRD) formerly known as the TAD or AM2. This circuit supplies +12 volts and the EEC shows the solenoid ground on pin #11. Use this diagram as a sample only. Always refer to specific wiring diagrams for the vehicle you are converting. See diagram left.

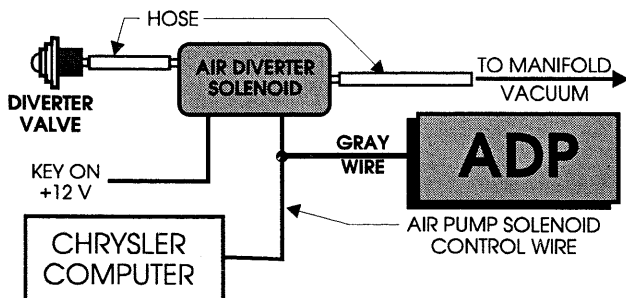

## CHRYSLER CORPORATION

Locate AIR diverter solenoid. Consult vehicle wiring diagram to determine which solenoid wire is the computer control wire. Connect ADP gray wire to this computer control wire. NOTE: Voltage on air diverter wire should be +12 volts when AIR injection system is **not** in operation. This same wire should read as ground when AIR system is in operation. See diagram left.

# ENGINE START UP MIXTURE ADJUSTMENTS

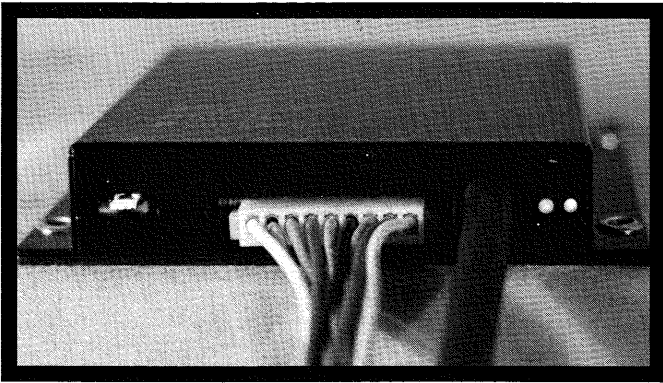

1. Be sure that the pin jumper is in place on the two right side pins. The left pins are for factory test mode only and are never used in the field. Turn key to the on position.

## **DO NOT START THE ENGINE!**

On the right side of the ADP unit, locate a green and red LED. With the key on and the engine off, the green LED will flash. This indicates the ADP is receiving power and is pulsing the FCV. Check the FCV. It should be clicking. If not recheck wiring to FCV valve. The red LED light should also be on indicating oxygen sensor output low (below .5 volts). If not; recheck oxygen sensor signal wire, and computer support output wire.

 **IF THE ENGINE AND OXYGEN SENSOR ARE HOT; VOLTAGE COULD BE ABOVE .5 VOLTS KEEPING THE RED LIGHT OFF FOR A SHORT PERIOD OF TIME.**

2. Connect the IMPCO fuel system analyzer (FSA-1) yellow lead to the FCV yellow wire. Connect the FSA-1 green lead to oxygen sensor output. Connect red to the battery positive, and black to negative.

3.  On the vehicles that inject air past the oxygen sensor, the air injection system must be disabled during the first 24 minutes of driving. Disconnect the air hose between the diverter valve, and exhaust manifold. Disconnect the gray wire connection..

## **START THE ENGINE**

4. Allow the engine to attain operational temperature. With no load on the engine, air conditioning off, lights off, and fans off, adjust the idle mixture screw on the IMPCO mixer/carburetor until the "Rich" and "Lean" lights on the FSA flash alternately.

In photo at left the duty cycle has been blocked. During this adjustment procedure, IGNORE THE READING ON THE DUTY CYCLE OF THE FSA-1. The duty cycle reading on the FSA-1 will remain fixed between 47% and 53% reading on the FSA-1 regardless of the adjustment. The duty cycle reading will not change until the jumper/shorting clip is removed in the next step.

Monitor the red LED on the ADP. This red LED should be turning on and off.

**NOTE:** The adjustment may become somewhat sensitive on engines equipped with the CA300 series of mixers. To lessen the effect of this, support the weight of the screwdriver with your hand. Do not press down on the idle adjustment screw of the 300 series mixer as this will tend to lean the mixture and give a false reading to the FSA-1, and the ADP.

After achieving oxygen sensor transitions, allow the engine to idle for 60 seconds, monitor the oxygen sensor lights on the FSA-1 or the ADP for transitions. Ignore the duty cycle reading during review.

